

Profile Dampers

The low cost alternative for continuous duty

The exceedingly successful TUBUS series from ACE is a perfect alternative, when masses don't need to be decelerated to an exact point. Available in more than 140 different versions, the profile dampers are used to slow down masses, particularly under extreme conditions.

They are also recommended for use if there is little installation space available. Manufactured in co-polyester elastomer, the highly resistant absorbers provide the best benefits in areas where other materials fail or where a similarly high service life of up to 1 million load changes cannot be achieved. They are affordable, compact and light and absorb the energy with different damping characteristics depending on the design.

Very good price/performance ratio

Reliable in extreme situations

Highly resistant material

Compact and lightweight design

Easy to mount

Long service life



Physical Properties of TUBUS Profile Dampers

ACE TUBUS profile dampers are high performance damping elements made from a special Co-Polyester Elastomer. They have a high energy absorbing capacity compared with other materials.

The excellent damping characteristics are achieved as a result of the special elastomer material and the worldwide unique construction design. This enables us to change the characteristics of the elastomer material so that individual and distinct damping curves are possible.

TUBUS dampers offer a considerable performance advantage when compared to other materials such as rubber, urethanes (PUR) and steel springs.

A further advantage compared to other damping elements is the operating life expectancy – up to twenty times longer than with urethane dampers, up to ten times longer than with rubber dampers and up to five times longer than with steel spring dampers.

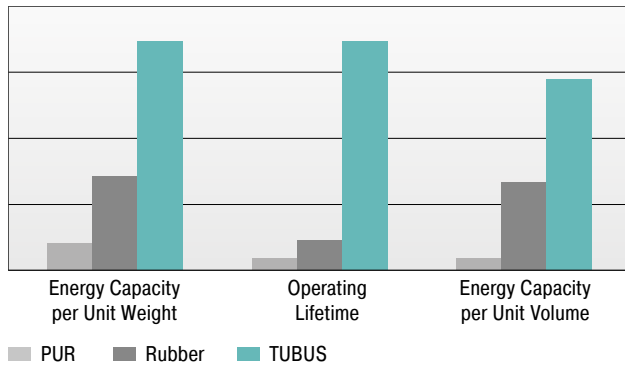

Comparison of Damping Characteristics

The innovative TUBUS dampers absorb energy while exhibiting the following damping characteristics:

Product family TA

Degressive characteristic with max. energy absorption with min. stroke.

Energy absorption: 58 % to 73 %

Product family TS

Almost linear characteristic with low reaction force over a short operating stroke.

Energy absorption: 35 % to 64 %

Product family TR/TR-L/TR-H

Progressive characteristic with gradually increasing reaction force over a long stroke.

Energy absorption TR: 25 % to 45 %

Energy absorption TR-L: 26 % to 41 %

Energy absorption TR-H: 39 % to 62 %

Product family TR-HD

Progressive characteristic with high energy absorption with a short stroke.

Energy absorption: 43 % to 72 %

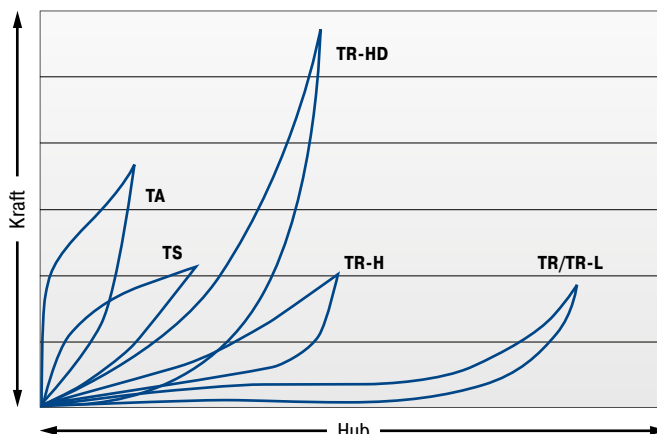

Characteristics of dynamic energy absorption for impact velocity over 0.5 m/s.

or impact velocities under 0.5 m/s, please request a static characteristic curve.

TUBUS TA, TS, TR, TR-H, TR-HD

TYPES	Max. Energy Capacity		Stroke max. mm	Page
	¹ W ₃ Nm/cycle	Emergency Stop W ₃ Nm/cycle		
TA12-5	2.0	3	5	101
TA17-7	6.0	9	7	101
TA21-9	10.0	16	9	101
TA22-10	11.5	21	10	101
TA28-12	29.0	46	12	101
TA34-14	48.0	87	14	101
TA37-16	65.0	112	16	101
TA40-16	82.0	130	16	101
TA43-18	112.0	165	18	101
TA47-20	140.0	173	20	101
TA50-22	170.0	223	22	101
TA54-22	201.0	334	22	101
TA57-24	242.0	302	24	101
TA62-25	304.0	361	25	101
TA65-27	374.0	468	27	101
TA70-29	421.0	524	29	101
TA72-31	482.0	559	31	101
TA80-32	570.0	831	32	101
TA82-35	683.0	921	35	101
TA85-36	797.0	1,043	36	101
TA90-38	934.0	1,249	38	101
TA98-40	1,147.0	1,555	40	101
TA116-48	2,014.0	2,951	48	101
TS14-7	2.0	3	7	103
TS18-9	4.0	6	9	103
TS20-10	6.0	7	10	103
TS26-15	11.5	15	15	103
TS32-16	23.0	26	16	103
TS35-19	30.0	36	19	103
TS40-19	34.0	42	19	103
TS41-21	48.0	63	21	103
TS44-23	63.0	72	23	103
TS48-25	81.0	91	25	103
TS51-27	92.0	114	27	103
TS54-29	122.0	158	29	103
TS58-30	149.0	154	30	103
TS61-32	163.0	169	32	103
TS64-34	208.0	254	34	103
TS68-36	227.0	272	36	103
TS75-39	291.0	408	39	103
TS78-40	352.0	459	40	103
TS82-44	419.0	620	44	103
TS84-43	475.0	635	43	103
TS90-47	580.0	778	47	103
TS107-56	902.0	966	56	103
TR29-17	1.2	1.8	17	105
TR37-22	2.3	5.4	22	105
TR43-25	3.5	8.1	25	105
TR50-35	5.8	8.3	35	105
TR63-43	12.0	17.0	43	105
TR67-40	23.0	33.0	40	105
TR76-46	34.5	43.0	46	105
TR83-50	45.0	74.0	50	105
TR85-50	68.0	92.0	50	105
TR93-57	92.0	122.0	57	105
TR100-60	115.0	146.0	60	105
TR30-15H	2.7	5.7	15	107
TR39-19H	6.0	18.0	19	107
TR45-23H	8.7	24.0	23	107
TR52-32H	11.7	20.0	32	107
TR64-41H	25.0	46.0	41	107
TR68-37H	66.5	98.0	37	107
TR79-42H	81.5	106.0	42	107
TR86-45H	124.0	206.0	45	107
TR87-46H	158.0	261.0	46	107
TR95-50H	228.0	342.0	50	107
TR102-56H	290.0	427.0	56	107
TR42-14HD	405	567	14	111
TR47-12HD	857	1,200	12	111
TR47-17HD	850	1,190	17	111
TR52-14HD	1,634	2,288	14	111
TR57-21HD	1,194	1,672	21	111

TUBUS TA, TS, TR, TR-H, TR-HD

TYPES	Max. Energy Capacity		Stroke max. mm	Page
	¹ W ₃ Nm/cycle	Emergency Stop W ₃ Nm/cycle		
TR62-15HD	2,940	4,116	15	111
TR62-19HD	2,940	4,116	19	111
TR63-24HD	2,061	2,885	24	111
TR72-26HD	1,700	2,380	26	111
TR79-20HD	2,794	3,912	20	111
TR79-31HD	2,975	4,165	31	111
TR85-33HD	2,526	3,536	33	111
TR89-21HD	4,438	6,213	21	111
TR90-37HD	3,780	5,292	37	111
TR93-24HD	3,421	4,789	24	111
TR97-31HD	7,738	10,833	31	111
TR97-35HD	2,821	3,949	35	111
TR102-44HD	4,697	6,576	44	111
TR105-28HD	5,641	7,897	28	111
TR117-30HD	8,457	11,840	30	111

¹ Max. energy capacity per cycle for continuous use.

TUBUS TR-L

TYPES	Max. Energy Capacity		Stroke max. mm	Page
	¹ W ₃ Nm/cycle	Emergency Stop W ₃ Nm/cycle		
TR29-17L	7.2	10.9	17	109
TR43-25L	14.0	32.7	25	109
TR63-43L	21.9	32.0	43	109
TR66-40L-1	102.0	143.0	40	109
TR66-40L-2	204.0	286.0	40	109
TR66-40L-3	306.0	428.0	40	109
TR66-40L-4	408.0	571.0	40	109
TR66-40L-5	510.0	714.0	40	109
TR76-45L-1	145.0	203.0	45	109
TR76-45L-2	290.0	406.0	45	109
TR76-45L-3	435.0	609.0	45	109
TR76-45L-4	580.0	812.0	45	109
TR76-45L-5	725.0	1,015.0	45	109
TR83-48L-1	180.0	252.0	48	109
TR83-48L-2	360.0	504.0	48	109
TR83-48L-3	540.0	756.0	48	109
TR83-48L-4	720.0	1,008.0	48	109
TR83-48L-5	900.0	1,260.0	48	109
TR99-60L-1	270.0	378.0	60	109
TR99-60L-2	540.0	756.0	60	109
TR99-60L-3	810.0	1,134.0	60	109
TR99-60L-4	1,080.0	1,512.0	60	109
TR99-60L-5	1,350.0	1,890.0	60	109
TR99-60L-6	1,620.0	2,268.0	60	109
TR99-60L-7	1,890.0	2,646.0	60	109
TR143-86L-1	600.0	840.0	86	109
TR143-86L-2	1,200.0	1,680.0	86	109
TR143-86L-3	1,800.0	2,520.0	86	109
TR143-86L-4	2,400.0	3,360.0	86	109
TR143-86L-5	3,000.0	4,200.0	86	109
TR143-86L-6	3,600.0	5,040.0	86	109
TR143-86L-7	4,200.0	5,880.0	86	109
TR188-108L-1	1,100.0	1,540.0	108	109
TR188-108L-2	2,200.0	3,080.0	108	109
TR188-108L-3	3,300.0	4,620.0	108	109
TR188-108L-4	4,400.0	6,160.0	108	109
TR188-108L-5	5,500.0	7,700.0	108	109
TR188-108L-6	6,600.0	9,240.0	108	109
TR188-108L-7	7,700.0	10,780.0	108	109

¹ Max. energy capacity per cycle for continuous use.

Issue 07.2017 – Specifications subject to change

Profile Dampers



TUBUS TA

Axial Damping

Compact size and strong force absorption

Linear slides, Pneumatic cylinders, Handling modules, Machines and plants

Page 100



TUBUS TS

Axial Soft Damping

Compact size and smooth deceleration

Linear slides, Pneumatic cylinders, Handling modules, Machines and plants

Page 102



TUBUS TR

Radial Damping

Compact size and soft deceleration

Furniture industry, Sports equipment, Linear slides, Pneumatic cylinders

Page 104



TUBUS TR-H

Radial Damping, Hard Version

Compact size with soft deceleration and high energy absorption

Furniture industry, Sports equipment, Linear slides, Pneumatic cylinders

Page 106



TUBUS TR-L

Radial Damping, Long Version

Powerhouse in long body length

Offshore industry, Agricultural machinery, Impact panels, Conveyor systems

Page 108



TUBUS TR-HD

Radial Damping, Heavy Duty Version

Compact powerhouse in solid material

Offshore industry, Agricultural machinery, Impact panels, Conveyor systems

Page 110

TUBUS TA

Compact size and strong force absorption

Axial Damping

Energy capacity 2 Nm/Cycle to 2,951 Nm/Cycle

Maximum stroke 5 mm bis 48 mm

Very efficient energy guzzlers: The TA profile dampers from the ACE TUBUS-Series are maintenance-free and ready to install. They consist of co-polyester elastomer; a material that only heats up slightly and ensures consistent damping. The TA models absorb a lot of energy at the start of the stroke.

The TA family has been specially developed for maximum energy absorption within a range of 2 Nm to 2,951 Nm. The minimum height is thanks to the space-saving shape with \varnothing 12 mm to \varnothing 116 mm. The dampers can be very easily and quickly fixed with the provided special screw.

These compact, cost-effective machine elements are ideal as end position dampers in linear axes, in toolmaking and tool machines, in hydraulic and pneumatic equipment, handling equipment and other applications.



Technical Data

Energy capacity: 2 Nm/Cycle to 2,951 Nm/Cycle

Energy absorption: 58 % to 73 %

Dynamic force range: 870 N to 90,000 N

Operating temperature range: -40 °C to +90 °C

Construction size: 12 mm to 116 mm

Mounting: In any position

Material hardness rating: Shore 55D

Material: Profile body: Co-Polyester Elastomer

Environment: Resistant to microbes, seawater or chemical attack. Excellent UV and

ozone resistance. Material does not absorb water or swell.

Impact velocity range: Max. 5 m/s

Torque max.:

M3: 1 Nm

M4: 1.7 Nm

M5: 2.3 Nm

M6: 6 Nm

M8: 20 Nm

M12: 50 Nm

M16: 120 Nm

Application field: Linear slides, Pneumatic cylinders, Handling modules, Machines and plants, Swivel units, Electro-mechanical

drives, Hydraulic devices, Conveyor systems, Crane systems

Note: Suitable for emergency stop applications and for continuous use. For applications with preloading and increased temperatures please consult ACE.

Safety instructions: Mounting screw should additionally be secured with Loctite.

On request: Special strokes, -characteristics, -spring rates, -sizes and -materials.

TA

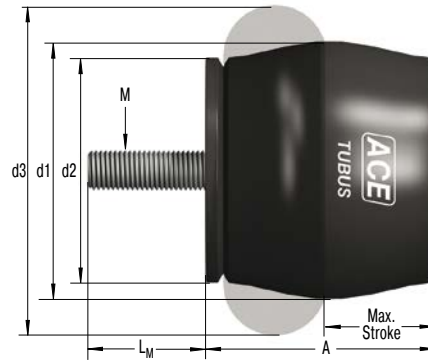

Characteristics

Type TA37-16
Energy-Stroke Characteristic (dynamic)
(with impact velocity over 0.5 m/s)

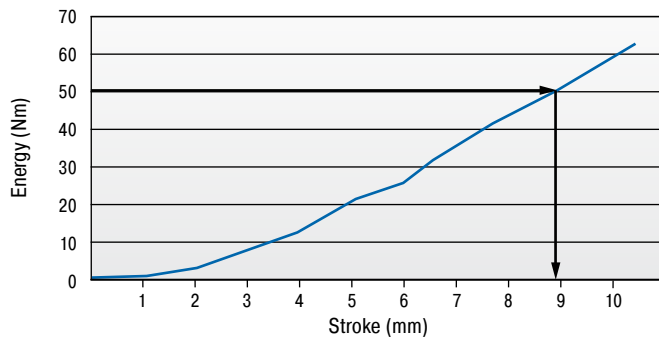

Type TA37-16
Force-Stroke Characteristic (dynamic)
(with impact velocity over 0.5 m/s)

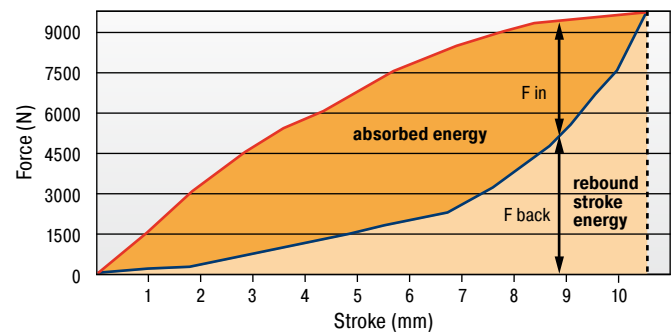

With the aid of the characteristic curves above you can estimate the proportion of the total energy that will be absorbed.
Example: With impact energy of 50 Nm the Energy-Stroke diagram shows that a stroke of about 8.8 mm is needed.
On the Force-Stroke diagram you can estimate the proportion of absorbed energy to rebound energy at this stroke length.
Dynamic ($v > 0.5$ m/s) and static ($v \leq 0.5$ m/s) characteristics of all types are available on request.

The calculation and selection of the most suitable damper should be carried out or be approved by ACE.

Ordering Example

TUBUS Axial _____ **TA37-16**
Outer-Ø 37 mm _____
Stroke 16 mm _____

Performance and Dimensions

TYPES	Emergency Stop		Stroke max. mm	A mm	d1 mm	d2 mm	d3 mm	L _M mm	M	Weight kg
	¹ W ₃ Nm/cycle	W ₃ Nm/cycle								
TA12-5	2.0	3	5	11	12	11	15	3	M3	0.001
TA17-7	6.0	9	7	16	17	15	22	4	M4	0.004
TA21-9	10.0	16	9	18	21	18	26	5	M5	0.007
TA22-10	11.5	21	10	19	22	19	27	6	M6	0.008
TA28-12	29.0	46	12	26	28	25	36	6	M6	0.016
TA34-14	48.0	87	14	30	34	30	43	6	M6	0.024
TA37-16	65.0	112	16	33	37	33	48	6	M6	0.030
TA40-16	82.0	130	16	35	40	34	50	8	M8	0.040
TA43-18	112.0	165	18	38	43	38	55	8	M8	0.051
TA47-20	140.0	173	20	41	47	41	60	12	M12	0.070
TA50-22	170.0	223	22	45	50	44	64	12	M12	0.085
TA54-22	201.0	334	22	47	54	47	68	12	M12	0.100
TA57-24	242.0	302	24	51	57	50	73	12	M12	0.116
TA62-25	304.0	361	25	54	62	53	78	12	M12	0.132
TA65-27	374.0	468	27	58	65	57	82	12	M12	0.153
TA70-29	421.0	524	29	61	70	60	86	12	M12	0.174
TA72-31	482.0	559	31	65	72	63	91	16	M16	0.257
TA80-32	570.0	831	32	69	80	69	100	16	M16	0.311
TA82-35	683.0	921	35	74	82	72	105	16	M16	0.350
TA85-36	797.0	1,043	36	76	85	75	110	16	M16	0.391
TA90-38	934.0	1,249	38	80	90	78	114	16	M16	0.414
TA98-40	1,147.0	1,555	40	86	98	85	123	16	M16	0.513
TA116-48	2,014.0	2,951	48	101	116	98	146	16	M16	0.803

¹ Max. energy capacity per cycle for continuous use.
All specifications are nominal dimensions. Tolerances are available on request.

TUBUS TS

Compact size and smooth deceleration

Axial Soft Damping

Energy capacity 2 Nm/Cycle to 966 Nm/Cycle

Maximum stroke 7 mm to 56 mm

Energy absorption in a compact and uniform way: The TS (TUBUS soft) profile dampers are also manufactured from co-polyester elastomer. Due to the almost linear damping characteristic curve, the maintenance-free, ready-to-install components softly absorb the energy with minimum strain on the machine. Consistent damping is helped by the low temperature increase of the material during operation.

The TS-Series impresses with maximum energy absorption within a range of 2 Nm to 966 Nm within a minimum height. The space-saving design has been implemented from Ø 14 mm to Ø 107 mm. The special screw supplied is used to simply and quickly fix the profile dampers in place.

Suitable for emergency stop and permanent applications, the cost-effective, durable TUBUS TS can be used as end position dampers in linear axes, in toolmaking and tool machines and in hydraulic, pneumatic and handling equipment.



Technical Data

Energy capacity: 2 Nm/Cycle to 966 Nm/Cycle

Energy absorption: 35 % to 64 %

Dynamic force range: 533 N to 23,500 N

Operating temperature range: -40 °C to +90 °C

Construction size: 14 mm to 107 mm

Mounting: In any position

Material hardness rating: Shore 40D

Material: Profile body: Co-Polyester Elastomer

Environment: Resistant to microbes, seawater or chemical attack. Excellent UV and

ozone resistance. Material does not absorb water or swell.

Impact velocity range: Max. 5 m/s

Torque max.:

M4: 1.7 Nm

M5: 2.3 Nm

M6: 6 Nm

M12: 50 Nm

M16: 120 Nm

Application field: Linear slides, Pneumatic cylinders, Handling modules, Machines and plants, Swivel units, Electro-mechanical drives, Crane systems, Conveyor systems, Crane systems

Note: Suitable for emergency stop applications and for continuous use. For applications with preloading and increased temperatures please consult ACE.

Safety instructions: Mounting screw should additionally be secured with Loctite.

On request: Special strokes, -characteristics, -spring rates, -sizes and -materials.

TS

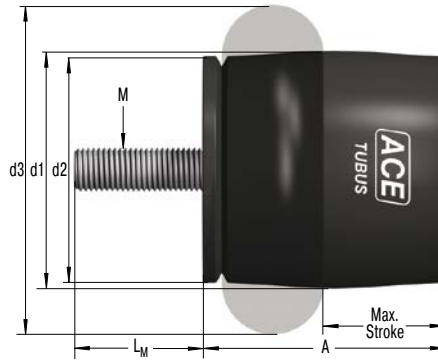

Characteristics

Type TS44-23
Energy-Stroke Characteristic (dynamic)
(with impact velocity over 0.5 m/s)

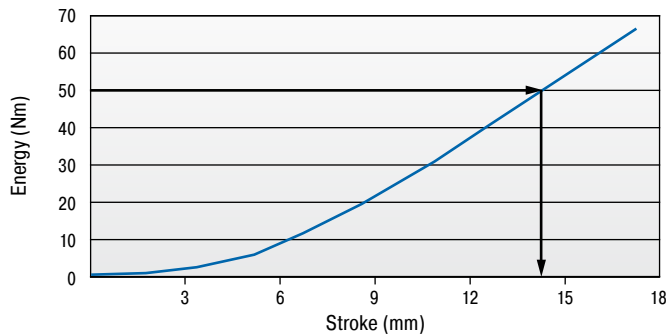

Type TS44-23
Force-Stroke Characteristic (dynamic)
(with impact velocity over 0.5 m/s)

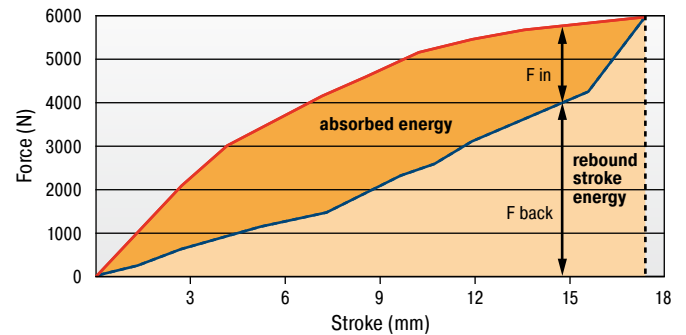

With the aid of the characteristic curves above you can estimate the proportion of the total energy that will be absorbed.
Example: With impact energy of 50 Nm the Energy-Stroke diagram shows that a stroke of about 14 mm is needed.
On the Force-Stroke diagram you can estimate the proportion of absorbed energy to rebound energy at this stroke length.
Dynamic ($v > 0.5$ m/s) and static ($v \leq 0.5$ m/s) characteristics of all types are available on request.

The calculation and selection of the most suitable damper should be carried out or be approved by ACE.

Ordering Example

TUBUS Axial Soft _____ **TS44-23**
Outer-Ø 44 mm _____
Stroke 23 mm _____

Performance and Dimensions

TYPES	Emergency Stop		Stroke max. mm	A mm	d1 mm	d2 mm	d3 mm	L _M mm	M	Weight kg
	¹ W ₃ Nm/cycle	W ₃ Nm/cycle								
TS14-7	2.0	3	7	15	14	13	19	4	M4	0.003
TS18-9	4.0	6	9	18	18	16	24	5	M5	0.006
TS20-10	6.0	7	10	21	20	19	27	6	M6	0.009
TS26-15	11.5	15	15	28	26	25	37	6	M6	0.016
TS32-16	23.0	26	16	32	32	30	44	6	M6	0.021
TS35-19	30.0	36	19	36	35	33	48	6	M6	0.028
TS40-19	34.0	42	19	38	40	34	51	6	M6	0.031
TS41-21	48.0	63	21	41	41	38	55	12	M12	0.060
TS44-23	63.0	72	23	45	44	40	60	12	M12	0.070
TS48-25	81.0	91	25	49	48	44	64	12	M12	0.080
TS51-27	92.0	114	27	52	51	47	69	12	M12	0.095
TS54-29	122.0	158	29	55	54	50	73	12	M12	0.105
TS58-30	149.0	154	30	59	58	53	78	12	M12	0.132
TS61-32	163.0	169	32	62	61	56	83	16	M16	0.203
TS64-34	208.0	254	34	66	64	60	87	16	M16	0.232
TS68-36	227.0	272	36	69	68	63	92	16	M16	0.248
TS75-39	291.0	408	39	75	75	69	101	16	M16	0.301
TS78-40	352.0	459	40	79	78	72	105	16	M16	0.339
TS82-44	419.0	620	44	84	82	75	110	16	M16	0.346
TS84-43	475.0	635	43	85	84	78	115	16	M16	0.402
TS90-47	580.0	778	47	92	90	84	124	16	M16	0.490
TS107-56	902.0	966	56	110	107	100	147	16	M16	0.733

¹ Max. energy capacity per cycle for continuous use.
All specifications are nominal dimensions. Tolerances are available on request.

TUBUS TR

Compact size and soft deceleration

Radial Damping

Energy capacity 1.2 Nm/Cycle to 146 Nm/Cycle

Maximum stroke 17 mm bis 60 mm

For long, soft braking action: The Radial damping forces in this model from the ACE TUBUS-Series provides the TR range. These maintenance-free, ready-to-install elements are made of co-polyester elastomer, which only heats up slightly during operation and therefore provides consistent damping.

The radial loading enables a very long and soft deceleration with progressive energy reduction at the end of the stroke. The TR-Series has been specially designed for maximum stroke with a minimum height, producing an energy absorption per stroke extending from 1.2 Nm to 146 Nm. The dampers are available in compact formats of Ø 29 mm to Ø 100 mm and are supplied with a special screw for simple, quick assembly.

The TUBUS TR products are suitable as end position dampers in linear axes, in toolmaking and tool machines, in hydraulic and pneumatic equipment, handling equipment and other applications.



Technical Data

Energy capacity: 1.2 Nm/Cycle to 146 Nm/Cycle

Energy absorption: 25 % to 45 %

Dynamic force range: 218 N to 7,500 N

Operating temperature range: -40 °C to +90 °C

Construction size: 29 mm to 100 mm

Mounting: In any position

Material hardness rating: Shore 40D

Material: Profile body: Co-Polyester Elastomer

Environment: Resistant to microbes, seawater or chemical attack. Excellent UV and ozone resistance. Material does not absorb water or swell.

Impact velocity range: Max. 5 m/s

Torque max.:

M5: 3 Nm

M6: 6 Nm

M8: 20 Nm

Application field: Furniture industry, Sports equipment, Linear slides, Pneumatic cylinders, Handling modules, Machines and plants, Stacking units, Electro-mechanical drives, Conveyor systems

Note: Suitable for emergency stop applications and for continuous use. For applications with preloading and increased temperatures please consult ACE.

Safety instructions: Mounting screw should additionally be secured with Loctite.

On request: Special strokes, -characteristics, -spring rates, -sizes and -materials.

TR

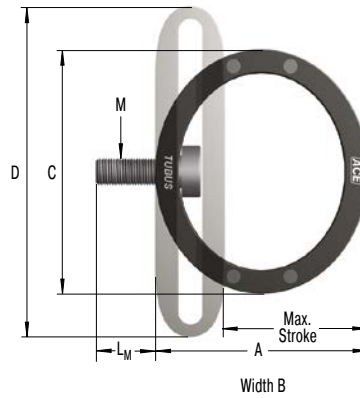

Characteristics

Type TR93-57

Energy-Stroke Characteristic (dynamic)
(with impact velocity over 0.5 m/s)

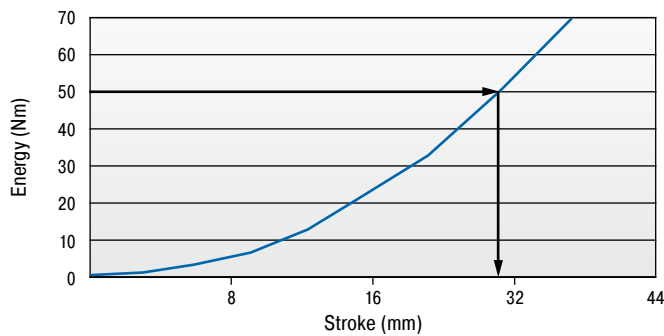

Type TR93-57

Force-Stroke Characteristic (dynamic)
(with impact velocity over 0.5 m/s)

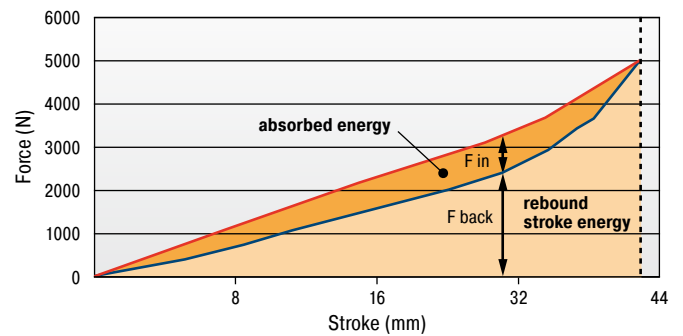

With the aid of the characteristic curves above you can estimate the proportion of the total energy that will be absorbed.
Example: With impact energy of 50 Nm the Energy-Stroke diagram shows that a stroke of about 31 mm is needed.
On the Force-Stroke diagram you can estimate the proportion of absorbed energy to rebound energy at this stroke length.
Dynamic ($v > 0.5$ m/s) and static ($v \leq 0.5$ m/s) characteristics of all types are available on request.

The calculation and selection of the most suitable damper should be carried out or be approved by ACE.

Ordering Example

TUBUS Radial _____ ↑
Outer-Ø 93 mm _____ ↑
Stroke 57 mm _____ ↑
TR93-57

Performance and Dimensions

TYPES	Emergency Stop		Stroke max. mm	A mm	B mm	C mm	D mm	L _M mm	M	Weight kg
	¹ W ₃ Nm/cycle	W ₃ Nm/cycle								
TR29-17	1.2	1.8	17	25	13	29	38	5	M5	0.010
TR37-22	2.3	5.4	22	32	19	37	50	5	M5	0.013
TR43-25	3.5	8.1	25	37	20	43	58	5	M5	0.017
TR50-35	5.8	8.3	35	44	34	50	68	5	M5	0.025
TR63-43	12.0	17.0	43	55	43	63	87	5	M5	0.051
TR67-40	23.0	33.0	40	59	46	67	88	5	M5	0.089
TR76-46	34.5	43.0	46	67	46	76	102	6	M6	0.104
TR83-50	45.0	74.0	50	73	51	83	109	6	M6	0.142
TR85-50	68.0	92.0	50	73	68	85	111	8	M8	0.206
TR93-57	92.0	122.0	57	83	83	93	124	8	M8	0.297
TR100-60	115.0	146.0	60	88	82	100	133	8	M8	0.308

¹ Max. energy capacity per cycle for continuous use.
All specifications are nominal dimensions. Tolerances are available on request.

TUBUS TR-H

Compact size with soft deceleration and high energy absorption

Radial Damping, Hard Version

Energy capacity 2.7 Nm/Cycle to 427 Nm/Cycle

Maximum stroke 15 mm bis 56 mm

Harder mixture of materials for higher energy absorption: The maintenance-free and ready-to-install TR-H-Series profile dampers, are stressed radially in the same way as the basic TR model. With almost the same dimensions, they also decelerate with a very long and soft action. The harder co-polyester elastomer mixture leads to significantly high energy absorption of 2.7 Nm to 427 Nm in these models. Easy to mount due to the supplied special screw.

The TR-H-Series is space-saving with dimensions of \varnothing 30 mm to \varnothing 102 mm. It complements the TUBUS range between the progressive TR and almost linear TS models. Users are therefore provided with a full range of deceleration curves within the ACE TUBUS family.

The TUBUS TR-H products are suitable end position dampers in linear axes, in toolmaking and tool machines and in hydraulic, pneumatic and handling equipment as well as other applications.



Technical Data

Energy capacity: 2.7 Nm/Cycle to 427 Nm/Cycle

Energy absorption: 39 % to 62 %

Dynamic force range: 550 N to 21,200 N

Operating temperature range: -40 °C to +90 °C

Construction size: 30 mm to 102 mm

Mounting: In any position

Material hardness rating: Shore 55D

Material: Profile body: Co-Polyester Elastomer

Environment: Resistant to microbes, seawater or chemical attack. Excellent UV and

ozone resistance. Material does not absorb water or swell.

Impact velocity range: Max. 5 m/s

Torque max.:

M5: 3 Nm

M6: 6 Nm

M8: 20 Nm

Application field: Furniture industry, Sports equipment, Linear slides, Pneumatic cylinders, Handling modules, Machines and plants, Stacking units, Electro-mechanical drives, Conveyor systems

Note: Suitable for emergency stop applications and for continuous use. For applications

with preloading and increased temperatures please consult ACE.

Safety instructions: Mounting screw should additionally be secured with Loctite.

On request: Special strokes, -characteristics, -spring rates, -sizes and -materials.

TR-H

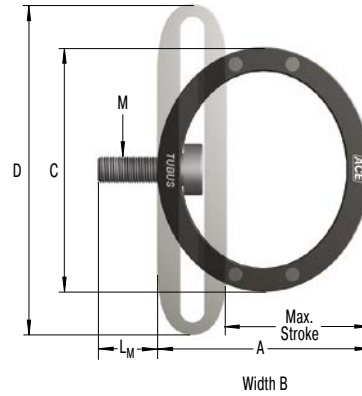

Characteristics

Type TR95-50H
Energy-Stroke Characteristic (dynamic)
(with impact velocity over 0.5 m/s)

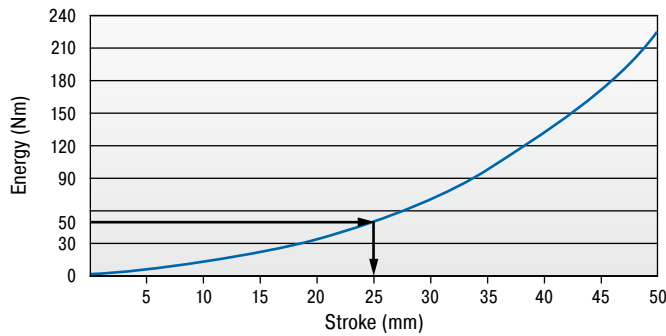

Type TR95-50H
Force-Stroke Characteristic (dynamic)
(with impact velocity over 0.5 m/s)

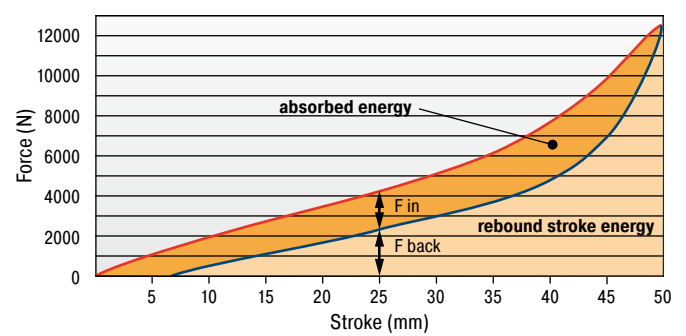

With the aid of the characteristic curves above you can estimate the proportion of the total energy that will be absorbed.
Example: With impact energy of 50 Nm the Energy-Stroke diagram shows that a stroke of about 25 mm is needed.
On the Force-Stroke diagram you can estimate the proportion of absorbed energy to rebound energy at this stroke length.
Dynamic ($v > 0.5$ m/s) and static ($v \leq 0.5$ m/s) characteristics of all types are available on request.

The calculation and selection of the most suitable damper should be carried out or be approved by ACE.

Ordering Example

TUBUS Radial _____ ↑ ↑ ↑
Outer-Ø 95 mm _____ ↑
Stroke 50 mm _____ ↑
Hard Version _____ ↑

TR95-50H

Performance and Dimensions

TYPES	Emergency Stop		Stroke max. mm	A mm	B mm	C mm	D mm	L _M mm	M	Weight kg
	¹ W ₃ Nm/cycle	W ₃ Nm/cycle								
TR30-15H	2.7	5.7	15	23	13	30	38	5	M5	0.009
TR39-19H	6.0	18.0	19	30	19	39	50	5	M5	0.013
TR45-23H	8.7	24.0	23	36	20	45	58	5	M5	0.019
TR52-32H	11.7	20.0	32	42	34	52	68	5	M5	0.030
TR64-41H	25.0	46.0	41	53	43	64	87	5	M5	0.054
TR68-37H	66.5	98.0	37	56	46	68	88	5	M5	0.095
TR79-42H	81.5	106.0	42	64	46	79	102	6	M6	0.107
TR86-45H	124.0	206.0	45	69	51	86	109	6	M6	0.152
TR87-46H	158.0	261.0	46	68	67	86	111	8	M8	0.188
TR95-50H	228.0	342.0	50	77	82	95	124	8	M8	0.281
TR102-56H	290.0	427.0	56	84	81	102	133	8	M8	0.334

¹ Max. energy capacity per cycle for continuous use.
All specifications are nominal dimensions. Tolerances are available on request.

TUBUS TR-L

Powerhouse in long body length

Radial Damping, Long Version

Energy capacity 7.2 Nm/Cycle to 10,780 Nm/Cycle

Maximum stroke 17 mm bis 108 mm

Especially for applications with long and soft deceleration: The radial tube dampers TR-L from the ACE TUBUS-Series are maintenance-free, ready-to-install elements made of co-polyester elastomer.

Their radial load offers designers a very long and soft deceleration with a progressive reduction in energy at the end of the stroke. The TR-L-Series has been specially developed for a maximum stroke with a minimum height and a range of 7.2 Nm to 10,780 Nm. The absorption capacity is dependent on the length of the selected tube damper. These models are available in sizes between \varnothing 29 mm and \varnothing 188 mm.

The TUBUS TR-L is used where impact or collision protection is necessary along a straight line e.g. on shovels in mining equipment, loading and lifting devices, dock systems in shipbuilding or luggage and transport belts.



Technical Data

Energy capacity: 7.2 Nm/Cycle to 10,780 Nm/Cycle

Energy absorption: 26 % to 41 %

Dynamic force range: 1,312 N to 217,700 N

Operating temperature range: -40 °C to +90 °C

Construction size: 29 mm to 188 mm

Mounting: In any position

Material hardness rating: Shore 55D

Material: Profile body: Co-Polyester Elastomer

Environment: Resistant to microbes, seawater or chemical attack. Excellent UV and

ozone resistance. Material does not absorb water or swell.

Impact velocity range: Max. 5 m/s

Torque max.:

M5: 3 Nm

M8: 20 Nm

M16: 40 Nm (DIN912)

M16: 120 Nm (shouldered screw)

Application field: Offshore industry, Agricultural machinery, Impact panels, Conveyor systems, Stacking units, Shipbuilding, Shovels or articulated joints for construction machinery, Transport roads, Loading and lifting equipment

Note: Suitable for emergency stop applications and for continuous use. For applications with preloading and increased temperatures please consult ACE.

Safety instructions: Mounting screw should additionally be secured with Loctite.

On request: Special strokes, -characteristics, -spring rates, -sizes and -materials.

TR-L

(middle hole only TR-L-5/6/7)

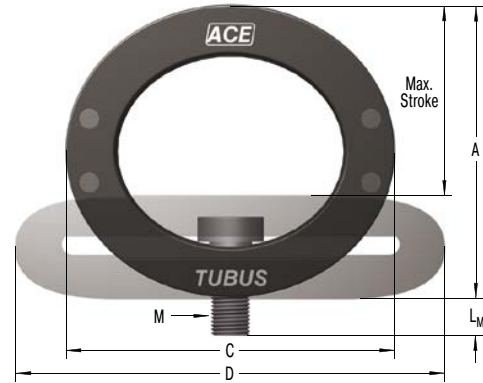
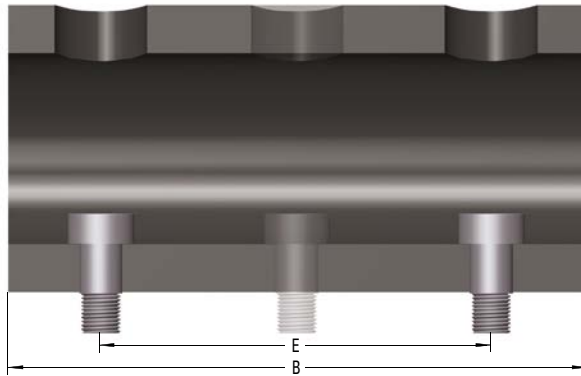

The calculation and selection of the most suitable damper should be carried out or be approved by ACE.

Ordering Example

TR66-40L-2

TUBUS Radial _____
 Outer-Ø 66 mm _____
 Stroke 40 mm _____
 Long Version _____
 Length 2 = 305 mm _____

Performance and Dimensions

TYPES	Emergency Stop		Stroke max. mm	A mm	B mm	C mm	D mm	E mm	L _M mm	M	Weight kg
	¹ W ₃ Nm/cycle	W ₃ Nm/cycle									
TR29-17L	7.2	10.9	17	25	80	29	38	40	5	M5	0.044
TR43-25L	14.0	32.7	25	37	80	43	58	40	5	M5	0.072
TR63-43L	21.9	32.0	43	55	80	63	87	40	5	M5	0.106
TR66-40L-1	102.0	143.0	40	59	152	66	87	102	8	M8	0.284
TR66-40L-2	204.0	286.0	40	59	305	66	87	254	8	M8	0.580
TR66-40L-3	306.0	428.0	40	59	457	66	87	406	8	M8	0.830
TR66-40L-4	408.0	571.0	40	59	610	66	87	559	8	M8	1.130
TR66-40L-5	510.0	714.0	40	59	762	66	87	711	8	M8	1.330
TR76-45L-1	145.0	203.0	45	68	152	76	100	102	8	M8	0.380
TR76-45L-2	290.0	406.0	45	68	305	76	100	254	8	M8	0.696
TR76-45L-3	435.0	609.0	45	68	457	76	100	406	8	M8	1.130
TR76-45L-4	580.0	812.0	45	68	610	76	100	559	8	M8	1.430
TR76-45L-5	725.0	1,015.0	45	68	762	76	100	711	8	M8	1.780
TR83-48L-1	180.0	252.0	48	73	152	83	106	102	8	M8	0.480
TR83-48L-2	360.0	504.0	48	73	305	83	106	254	8	M8	0.930
TR83-48L-3	540.0	756.0	48	73	457	83	106	406	8	M8	1.380
TR83-48L-4	720.0	1,008.0	48	73	610	83	106	559	8	M8	1.810
TR83-48L-5	900.0	1,260.0	48	73	762	83	106	711	8	M8	2.260
TR99-60L-1	270.0	378.0	60	88	152	99	130	102	8	M8	0.790
TR99-60L-2	540.0	756.0	60	88	305	99	130	254	8	M8	1.290
TR99-60L-3	810.0	1,134.0	60	88	457	99	130	406	8	M8	1.940
TR99-60L-4	1,080.0	1,512.0	60	88	610	99	130	559	8	M8	2.660
TR99-60L-5	1,350.0	1,890.0	60	88	762	99	130	711	8	M8	3.100
TR99-60L-6	1,620.0	2,268.0	60	88	914	99	130	864	8	M8	3.700
TR99-60L-7	1,890.0	2,646.0	60	88	1,067	99	130	1,016	8	M8	4.300
TR143-86L-1	600.0	840.0	86	127	152	143	191	76	22	M16	1.440
TR143-86L-2	1,200.0	1,680.0	86	127	305	143	191	203	22	M16	2.900
TR143-86L-3	1,800.0	2,520.0	86	127	457	143	191	355	22	M16	3.880
TR143-86L-4	2,400.0	3,360.0	86	127	610	143	191	508	22	M16	5.420
TR143-86L-5	3,000.0	4,200.0	86	127	762	143	191	660	22	M16	6.590
TR143-86L-6	3,600.0	5,040.0	86	127	914	143	191	812	22	M16	7.890
TR143-86L-7	4,200.0	5,880.0	86	127	1,067	143	191	965	22	M16	9.190
TR188-108L-1	1,100.0	1,540.0	108	165	152	188	245	76	26	M16	2.340
TR188-108L-2	2,200.0	3,080.0	108	165	305	188	245	203	26	M16	4.640
TR188-108L-3	3,300.0	4,620.0	108	165	457	188	245	355	26	M16	6.890
TR188-108L-4	4,400.0	6,160.0	108	165	610	188	245	508	26	M16	9.190
TR188-108L-5	5,500.0	7,700.0	108	165	762	188	245	660	26	M16	11.390
TR188-108L-6	6,600.0	9,240.0	108	165	914	188	245	812	26	M16	13.640
TR188-108L-7	7,700.0	10,780.0	108	165	1,067	188	245	965	26	M16	15.940

¹ Max. energy capacity per cycle for continuous use.

All specifications are nominal dimensions. Tolerances are available on request.

TUBUS TR-HD

Compact powerhouse in solid material

Radial Damping, Heavy Duty Version

Energy capacity 405 Nm/Cycle to 11,840 Nm/Cycle

Maximum stroke 12 mm to 44 mm

Impact and collision protection: The TR-HD profile dampers are stressed in the same way as the basic model TR but offer a higher force and energy absorption with a shorter damping distance thanks to the solid design. Different damping characteristic curves can be achieved with two different co-polyester elastomer hardness levels. The slightly oval (bi-concave) shape also ensures a softer force intake.

This series absorbs a lot of energy despite the low height: a range of 405 Nm to 11,840 Nm is progressively covered by strokes of 12 mm to 44 mm. With two screws, included in the delivery, the damper can be easily and quickly fixed both horizontally or vertically. The drill hole distance is adapted if required.

These dampers are used in agricultural technology and on shovels or break joints on construction machines as well as on loading and lifting or similar equipment.



Technical Data

Energy capacity: 405 Nm/Cycle to 11,840 Nm/Cycle

Energy absorption: 43 % to 72 %

Dynamic force range: 78.800 N to 812,900 N

Operating temperature range: -40 °C to +90 °C

Construction size: 42 mm to 117 mm

Mounting: In any position

Material hardness rating: Shore 40D, Shore 55D

Material: Profile body: Co-Polyester Elastomer

Environment: Resistant to microbes, seawater or chemical attack. Excellent UV and ozone resistance. Material does not absorb water or swell.

Impact velocity range: Max. 5 m/s

Torque max.:

M10: 7 Nm

M12: 12 Nm

Application field: Offshore industry, Agricultural machinery, Impact panels, Conveyor systems, Stacking units, Shipbuilding, Shovels or articulated joints for construction machinery, Transport roads, Loading and lifting equipment

Note: Suitable for emergency stop applications and for continuous use. For applications with preloading and increased temperatures please consult ACE.

Safety instructions: Mounting screw should additionally be secured with Loctite.

On request: Special strokes, -characteristics, -spring rates, -sizes and -materials.

TR-HD

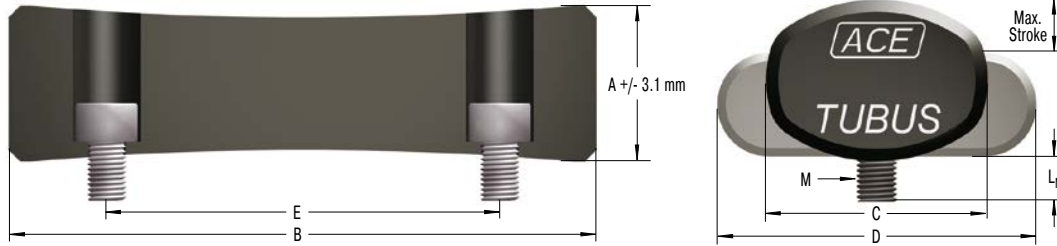

Characteristics

TUBUS TR-HD

Force-Stroke Characteristics (static)

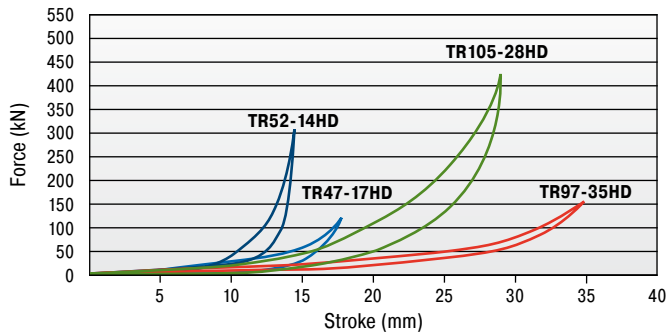

The calculation and selection of the most suitable damper should be carried out or be approved by ACE.

Ordering Example

TUBUS Radial _____
Outer-Ø 63 mm _____
Stroke 24 mm _____
Heavy Duty Version _____

TR63-24HD

Performance and Dimensions

TYPES	Emergency Stop		F max. static N	Stroke max. mm	A mm	B mm	C mm	D mm	E mm	L _M mm	M	Weight kg
	¹ W ₃ Nm/cycle	W ₃ Nm/cycle										
TR42-14HD	405	567	63,900	14	34	148	42	59	102	20	M10	0.170
TR47-12HD	857	1,200	149,600	12	31	150	47	58	102	19	M10	0.170
TR47-17HD	850	1,190	122,100	17	32	150	47	70	102	24	M10	0.180
TR52-14HD	1,634	2,288	304,500	14	29	153	52	69	102	22	M10	0.180
TR57-21HD	1,194	1,672	104,800	21	48	149	57	79	102	18	M10	0.340
TR62-15HD	1,790	2,506	245,000	15	40	153	62	77	102	16	M10	0.330
TR62-19HD	2,940	4,116	389,900	19	41	152	62	94	102	16	M10	0.360
TR63-24HD	2,061	2,885	194,400	24	46	153	63	92	102	20	M10	0.330
TR72-26HD	1,700	2,380	124,800	26	59	149	72	98	102	23	M12	0.560
TR79-20HD	2,794	3,912	289,300	20	54	153	79	98	102	24	M12	0.570
TR79-31HD	2,975	4,165	226,600	31	58	155	79	112	102	23	M12	0.560
TR85-33HD	2,526	3,536	146,100	33	71	150	85	111	102	23	M12	0.710
TR89-21HD	4,438	6,213	477,400	21	48	162	89	112	102	22	M12	0.560
TR90-37HD	3,780	5,292	240,700	37	69	155	90	128	102	23	M12	0.750
TR93-24HD	3,421	4,789	302,500	24	64	155	93	115	102	23	M12	0.790
TR97-31HD	7,738	10,833	575,200	31	63	159	97	129	102	21	M12	0.800
TR97-35HD	2,821	3,949	152,800	35	82	151	97	131	102	20	M12	1.060
TR102-44HD	4,697	6,576	254,500	44	81	156	102	147	102	22	M12	1.050
TR105-28HD	5,641	7,897	427,600	28	72	156	105	126	102	21	M12	1.000
TR117-30HD	8,457	11,840	639,100	30	66	166	117	143	102	25	M12	1.010

¹ Max. energy capacity per cycle for continuous use.
All specifications are nominal dimensions. Tolerances are available on request.

Application Examples

TUBUS TA

Safe end position damping

ACE TUBUS profile dampers protect the integrated loading station on a new high speed machining centre. The ACE TUBUS damper is designed to prevent overrun on the high speed loading station of a Camshaft machining centre used in the automobile industry. In the event that the drive train fails during operation or incorrect data is inputted the ACE TUBUS damper absorbs the impact preventing costly damage to the machine. The TA98-40 TUBUS damper impressed engineers with this exceptionally long service life in operation. When used as an emergency stop the TUBUS damper can absorb up to 73 % of the impact energy.



Safety with ultra high speed operation

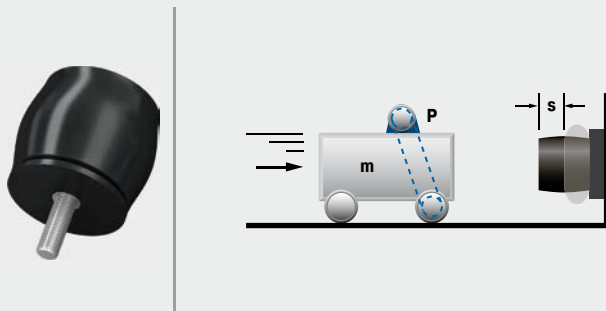

TUBUS TS

Safe braking of maintenance boats

The maintenance of wind turbines in open seas has long resulted in damage to maintenance boats. Because of impact velocity and swell, an increase in the boat's mass of up to 20 percent must be taken into account when landing on a rigid mooring structure. It is only since the landing operation has been carried out with the aid of the ACE company's TUBUS series that cable repair and maintenance work on wind turbines has been made safe for both personnel and equipment. TUBUS of the type TS84-43 are seawater resistant and can withstand ambient temperatures from -40 °C to + 90 °C.



Seawater-resistant, robust TUBUS profile dampers made of co-polyester elastomer allow boats and crew to dock safely
Wals Diving and Marine Service, 1970AC Ijmuiden, Netherlands

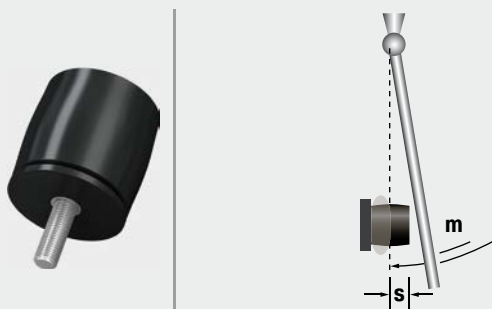

TUBUS TS

Protection of drive used in space treadmill

When training in zero gravity, a harness with bungee cords is used to ensure that trainees do not become disengaged. Three ACE profile dampers with a linear-working facility are utilized in this case. One so-called TUBUS is positioned in the pneumatic cylinder, while the other two are put in place in the rest of the system. All the dampers have the task of protecting the system if the treadmill drive belts become damaged. Otherwise, the cylinder would reach a very high speed and become seriously damaged at the end of the stroke.



TUBUS are used to protect a fitness machine in zero gravity
QinetiQ Space nv, 9150 Kruibeke, Belgium

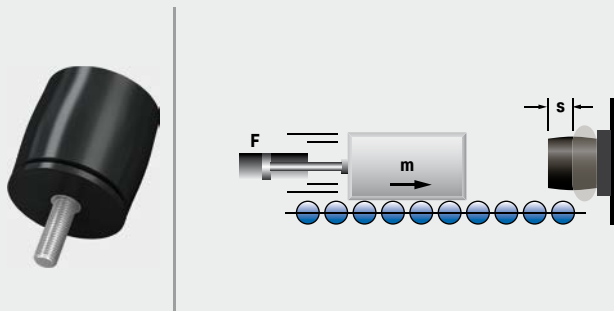

TUBUS TR

Gentle damping for electric scooters

TUBUS profile dampers make driving an e-scooter a real experience. The footboard of an electric scooter should be dampened to enable the driver to experience a comfortable ride even over potholes and other bumpy surfaces. Ideally, the characteristic line should be furnished with a soft increase in force over a long stroke. The elegant look of the scooter as well as the folding mechanism designed to save space have not allowed the use of feasible damper solutions up to now. Inferior alternatives such as rubber dampers made of polyurethane or simple steel springs could not be considered from the start. The TUBUS profile damper TR52-32H offered the perfect solution with its compact construction design paired with progressive damping action.



Profile dampers increase the riding comfort of an electric scooter

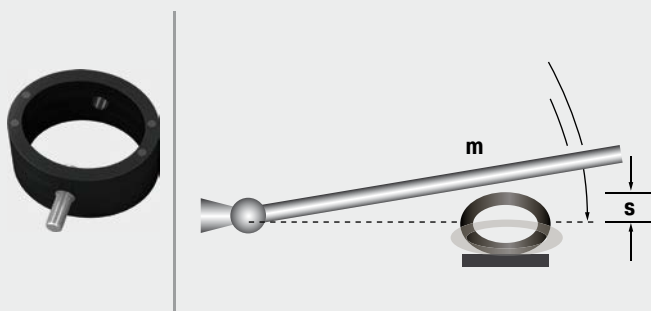

Special Profile Dampers

Costs-effective tuning for your pressing tools

ACE provides TUBUS profile dampers in many variations. Special solutions for presses can now be cost-effectively achieved with down holder dampers, damping plugs, lift dampers and press dampers from ACE.

They replace the PU-springs previously used in the automotive industry. It was no longer possible for them to fulfil the required tasks due to the higher return stroke speeds in modern pressing tools. Made of co-polyester elastomers, the TUBUS special takes care of the protection of mounting bolts and insert bolts much more reliably. On the one hand they protect a so-called down holders during the return stroke after the forming of sheet metal parts, and on the other they function as protection for hoisting lifters.

High reliability

Long service life

High power and energy absorption

Efficient working through higher cycle rates

Extreme abrasion hardness and shear strength

Noise reduction

